

- Powerful Heat -

## VISTAFLAME VF55 MULTI-FUEL STOVE



**VISTAFLAME**



HEARTH PRODUCTS

**WARM UP TO A VISTAFLAME!**

# THE VISTAFLAME VF55



**Optional Ceramic Log Set -**  
Finely crafted, realistic looking ceramic log set gives a new dimension to the pellet fire.



**Standard Wall Thermostat -**  
The VF55 comes with a standard wall thermostat.



**Optional Wireless Digital Wall Thermostat or Remote Control -**  
An optional wireless digital Wall Thermostat and remote control are available for the VF55.



**Optional Fluted Cast Iron Firebox Liner -**  
Detailed, durable and decorative heavy-gauge construction.



**Tri-mode Control System -**  
You can operate the VF55 in three different modes -  
1. Manual Mode  
2. Hi/Lo Mode  
3. Auto/Off Mode



**Premium Pellets, Regular Pellets or Alternate Fuels -**  
With the touch of a button you can change fuel type - Super Premium, Premium, Standard Pellets, Utility Pellets or Alternate Fuels - from wood pellets, corn, wheat, barley, paper pellets to all bark pellets



**Optional Hopper Extension Kit -**  
Extends Hopper to twice the size - up to 160 lbs (4 x 40 lb bags of pellets!)







### Nicest Pellet Flame in the Industry!

Compare our fire with what you see in other stoves. We think that none can even come close to matching the size, beauty, and efficiency of the VF55's flame.



### Heating Area -

Heats up to 2500 sq. ft. at 78% efficiency.



### Low Maintenance Burner -

This patent pending technology has an agitator rod in the burn pot that breaks up any clinker or ash and helps move it into the ash pan. This greatly reduces cleaning intervals and also allows you to burn lesser quality, inexpensive pellets and alternate fuels.



### Large Hopper -

Large 80 lb. hopper for up to 48 hrs. continuous burning time.



### Quietest Pellet Stove in the Industry -

Capacitor-driven motor gives very low noise readings - 40 - 45 dB (at 10 ft. away).



### Quick Start Ignitor -

400 Watt Ignitor with air pump for quick starts.



### Large Ash Pan -

Larger ash pan allows for longer periods between cleanings.



### Welded Heat Exchanger -

Each heat exchanger tube is individually welded in for extra durability.



### Standard Wooden Handle -

The VF55 comes standard with a traditional looking wooden handle.



VF55

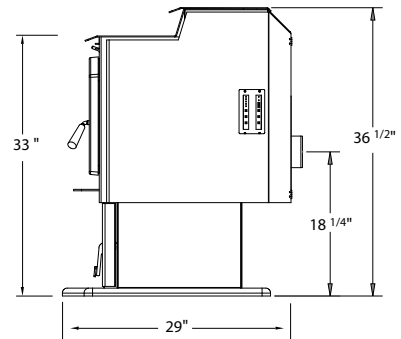
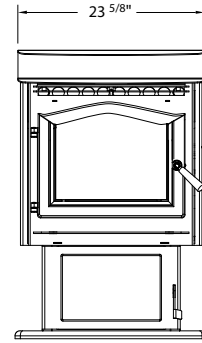

## SPECIFICATIONS

Convection Fan (variable speed)	200 CFM
Ignitor	400 Watt
Fuel Capacity	80 lbs.
Weight (empty)	300 lbs.
Btu input (on high)*	55,000
Btu input (on low)*	10,000
Max. Power usage (ignitor on)	600 Watt
EPA Efficiency Rating**	78 %
EPA Approved**	2.3 g per hour
Area Heated***	up to 2500 sq. ft.
Vent Size	4"
Glass Size	163 sq. in.

## FEATURES

Standard Wall Thermostat
Air Wash System for cleaner glass
Mobile Home Approved
Built-in floor protection - no hearth pad required
Warranty - see dealer for our extensive warranty.

## CLEARANCES

Side wall to unit	12"
Back wall to unit	3"
Wall to corner of unit	3"
Floor protector (in front of door opening)	6"

## OPTIONS

Wireless Digital Wall Thermostat or Remote Control
Fluted Liner
Ceramic Log Set
Hopper Extension Kit
Turbo Fan

\* Figures will vary considerably with individual conditions and fuel quality. \*\* Preliminary results. \*\*\* Figures will vary considerably with floor plan, house layout and heat loss of the house.



• Manufactured by Sherwood Industries Ltd., Victoria, BC, Canada •

Printed in Canada July, 2009

Please share and recycle this brochure

